

## Triple Serial LED Driver PR4130 and LED controller PR4230 With Integrated LED Break Detection and Bypass Function

### Features

- Drives up to 3 LEDs in series
- Programmable current sink for 5 to 30mA (only PR4130)
- Checks LED current and by-passes broken LEDs
- A broken LED break does not lead to a black-out of a complete LED string
- Compatible with all LED colors (red, yellow, green, blue, white, UV)
- Minimum number of external components required

### Applications

- Decoration string lights
- LCD backlighting units
- Third (High Mounted) Brake Lights

### Block Diagrams

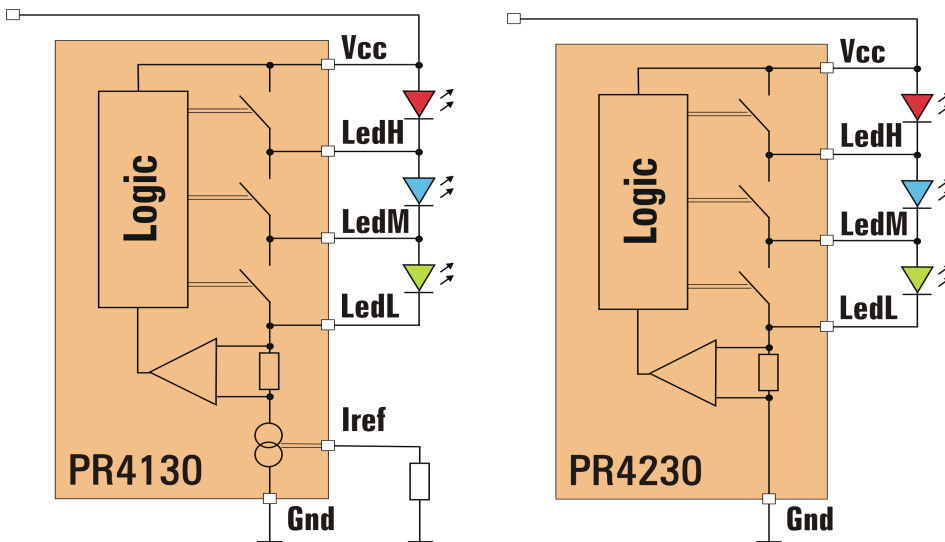

### Typical Applications

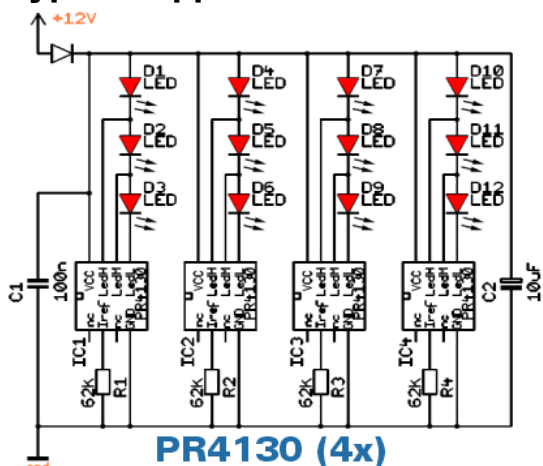

4 chains of 3 LEDs each are driven in parallel

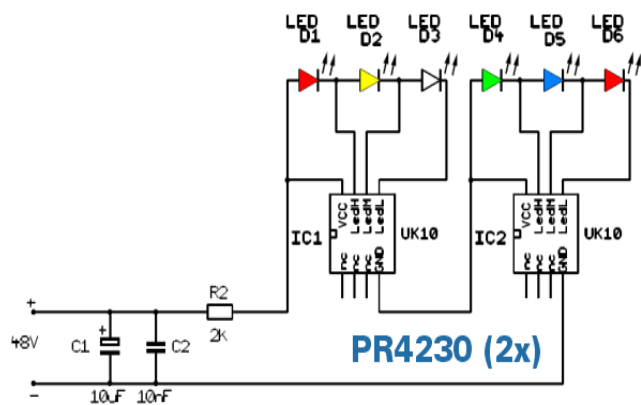

Driving LEDs of different colors

## Typical Application PR4230

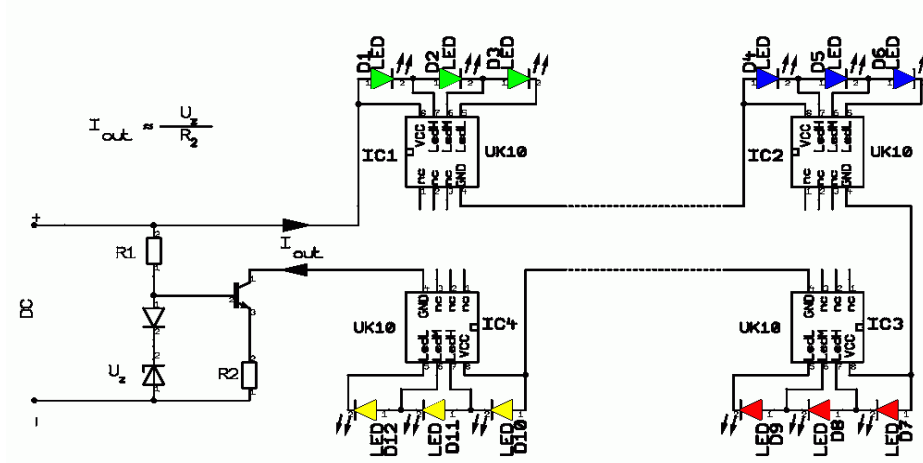

Decoration string light for 230Vac (Driving 78 green LEDs in series (PR4230))

## Functional Description

Normally, if LEDs are driven in series, a failure in one LED will lead to the malfunction of the whole chain. The Triple LED driver PR4130 as well as the LED controller PR4230 supervises the current through the LED chain and bypasses all defective LEDs, keeping the remaining LEDs functional. If an anomaly in the current through the LED chain is detected, it tries to re-establish the current flow by bypassing different LEDs and combinations of LEDs. The maximum test time is 1.4ms.

In addition, the PR4130 provides a constant current sink, keeping the LED current independent of  $V_{CC}$  and the number of LEDs in a string.

## Pin Assignment

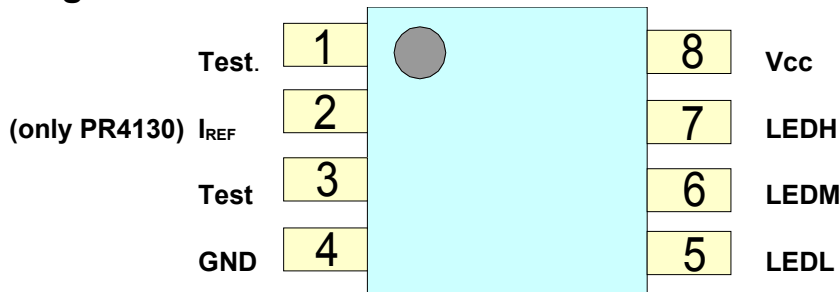

PR4130 / PR4230 in SO8 package

PIN No	PIN Name	PIN Function Description
1	test	do not connect
2	$I_{REF}$	Reference Current (only PR4130) / do not connect for PR4230
3	test	do not connect
4	GND	Ground
5	LEDL	LED Low
6	LEDM	LED Mid
7	LEDH	LED High
8	$V_{CC}$	Input Voltage

## Absolute Maximum Ratings

Parameter	Min	Max	Units
V <sub>CC</sub>	-0.3	18,5	V
Output Current	0	100	mA
Operating Junction Temperature Range	-20	125	°C
Storage Temperature Range	-40	150	°C

## Electrical Characteristics

Conditions: V<sub>CC</sub>=12.4V; T<sub>a</sub>=22.5°C unless otherwise indicated

LED Current as a function of the reference resistor only for PR4130

R <sub>REF</sub>	I <sub>LED</sub>
332 kΩ	5 mA ± 5%
157 kΩ	10 mA ± 5%
74 kΩ	20 mA ± 5%
48 kΩ	30 mA ± 5%

Parameter	Conditions	Min	Typ	Max	Units
Supply Voltage V <sub>CC</sub>		7.0		18.0	V
LED Current I(LED <sub>L</sub> )		4.5		33	mA
V(LED <sub>H</sub> ), V(LED <sub>M</sub> ), V(LED <sub>L</sub> )	switch off (current flow through LED)			V <sub>CC</sub>	V
Clamping voltage V <sub>CC</sub> -V(LED <sub>H</sub> ), V(LED <sub>H</sub> )-V(LED <sub>M</sub> ), V(LED <sub>M</sub> )-V(LED <sub>L</sub> )	switch on (current flow through switch)			2.6	V
Voltage at I <sub>ref</sub> pin			4.4		V
V <sub>CC</sub> clamping voltage		18.4			V
Current through V <sub>CC</sub> clamping diode				100	mA

## Application Note for PR4130

### Operation with PWM Control

As a zero LED current state may interfere with the break detection sequence, it should be avoided to switch the LED completely on and off to control brightness by a PWM signal.

It is however possible to switch between minimum and maximum current by switching the reference current I<sub>ref</sub> with a PWM signal - see drawing.

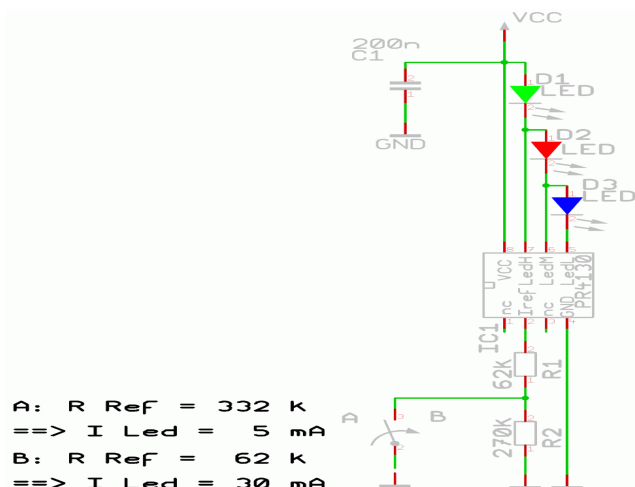

## Mechanical Dimensions of a SO8 package

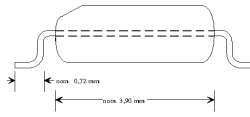
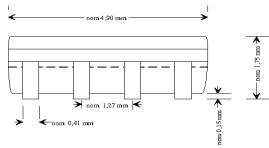

All parts delivered comply with RoHS.  
Finish is pure tin.

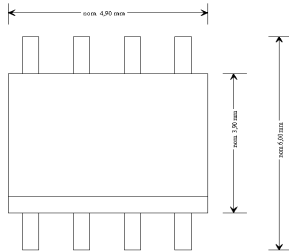

## Thermal Design

Worst-case conditions for the power are when all LEDs are broken, so the full voltage drops along the IC. Roughly the power can be calculated as the product of supply voltage and LED current, neglecting the current consumption by the PR4130 / PR4230 itself. Values for maximum power are given for parts in SO-8 package.

$T_a$	$P_{max}$
25°C	550 mW
50°C	420 mW
75°C	280 mW
100°C	140 mW

## Disclaimer

Information provided by PREMA is believed to be accurate and correct. However, no responsibility is assumed by PREMA for its use, nor for any infringements of patents or other rights of third parties which may result from its use. PREMA reserves the right at any time without notice to change circuitry and specifications.

## Life Support Policy

PREMA Semiconductors products are not authorized for use as critical components in life support devices or systems without the express written approval of PREMA Semiconductor. As used herein:

1. Life support devices or systems are devices or systems which, (a) are intended for surgical implant into the body, or (b) support or sustain life, and whose failure to perform when properly used in accordance with instructions for use provided in the labeling, can be reasonably expected to result in a significant injury to the user.
2. A critical component is any component of a life support device or system whose failure to perform can be reasonably expected to cause the failure of the life support device or system, or to affect its safety or effectiveness.

## PREMA Semiconductor GmbH

Robert-Bosch-Str. 6

55129 Mainz Germany

Phone: +49-6131-5062-0

Fax: +49-6131-5062-220

Email: [prema@prema.com](mailto:prema@prema.com)

Web site: [www.prema.com](http://www.prema.com)